



ITT

Water & Wastewater

# Design recommendations

for pump stations with midrange  
centrifugal Flygt wastewater pumps



*Engineered for life*

# Contents

|   |   |
|---|---|
| <b>General principles</b> .....                     | 2 |
| Pump sump .....                                     | 3 |
| Intake .....  | 3 |
| Distance, pump inlet to sump bottom .....           | 3 |
| Sump design recommendation for greater inflow ..... | 3 |
| <b>Sump dimensions</b> .....                        | 4 |
| Required volumes .....                              | 6 |
| Calculating the active sump volume .....            | 6 |
| <b>Systems Engineering</b> .....                    | 7 |

---

This document is intended for designers, planners and users of sewage and storm-water pumping systems that incorporate the range of 3152-3301 (20 l/s – 350 l/s) Flygt submersible pumps.

The pump and sump are parts of an overall system that also includes a variety of structures and other elements such as the pipe system, ventilation systems and handling equipment. Operating costs can be reduced with the help of effective planning during the design stage and with optimised operation schedules. The proper design of the pump sump is crucial in order to achieve an optimal environment for the pumps. This brochure illustrates designs of midrange pump stations that meet these requirements. For pump station recommendations outside the scope of this brochure, please refer to your local ITT Water & Wastewater representative.

The design recommendations are only valid for Flygt products. ITT Water & Wastewater assumes no liability for non-Flygt products.

## General principles

The purpose of a sump design is to ensure proper approach flow to the pumps and prevent the accumulation of sediment and surface scum. The sump should also be big enough to prevent flooding. If the sump is not designed correctly, the hydraulic environment may affect the pump operation –resulting in diminished design performance, and reduced pump life. To ensure that the pump operates in a suitable environment, some general points must be considered:

- Flow of water from the inlet of the sump should be directed towards the pump inlet.
- The flow is uniform without swirl or air entrainment.
- The walls must be designed and built to avoid stagnation regions in order to prevent the formation of air-entraining surface vortices and sediment accumulation.
- The water depth must be great enough to suppress surface vortices.
- Excessive turbulence or large eddies should be avoided, although a minor amount of turbulence helps to prevent the formation and growth of vortices.

## Pump sump

One problem that can occur in a waste water pump station is the build up of sludge and solids of different densities. To overcome this ITT Water & Wastewater has developed a self-cleaning sump design, called the TOP sump.

The patented hydraulic design prevents any dead zones at the bottom by promoting fluid flow throughout the sump during pumping. The resulting increase in turbulence causes re-suspension of sludge, settled solids and entrainment of floating debris. The reduction in the build-up of sludge diminishes the risk of formation of noxious gases. This brochure recommends a design for midrange Flygt pump sumps based on the TOP concept.

## Pump station intake

Proper positioning of the intake is crucial in order to ensure a good hydraulic environment for the pumps and to guarantee efficient operation. Preferably the intake is positioned within a 120-degree sector on the opposite side of the discharge pipes (see the illustrations on the page 5). If the intake is located high above the water surface, a pipe leading the water down to a lower level is advisable to prevent cascading flow and air entrainment during the pump cycle. Also, it is recommended that inlet velocities to the sump is between 0,7 – 1,8 m/s.



*Circular sump design*

## Distance between pump inlet and sump bottom

To provide the best possible inflow to the pump, the minimum distance from the bottom of the sump to the pump shall be 40% of the inlet diameter, provided there is no risk of trapping larger objects between the inlet and the sump floor. To achieve this bottom clearance, sometimes the discharge connection needs to be mounted on a concrete plinth. For information about clearance distance, please refer to the dimensional drawings for each individual pump model.

## Sump design recommendation for greater inflow

For pump stations with larger inflows it may be necessary to use a rectangular sump. To ensure good hydraulic conditions in a rectangular sump the walls should be sloped in the same way as in a circular sump. It is also advised to have an inlet baffle located by the sump intake, providing a good hydraulic environment for the pumps.

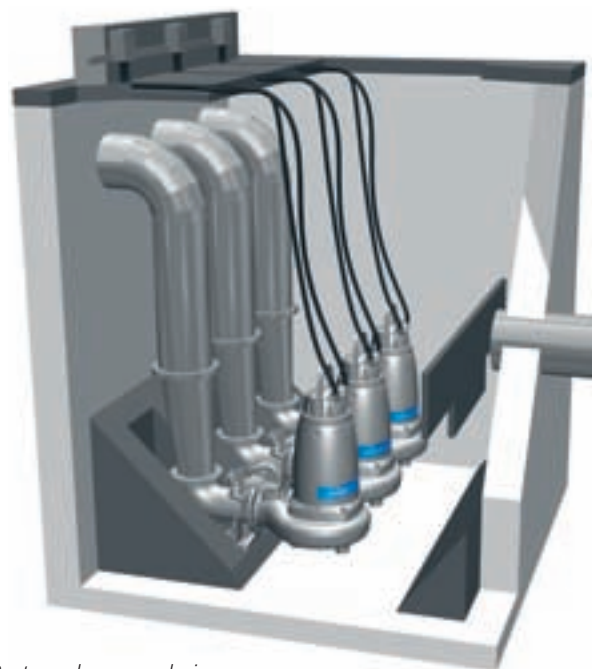

*Rectangular sump design*

# Sump dimensions

All measurements are in mm.

| A<br>(mm) | M<br>(mm) | N<br>(mm) | P<br>(mm) | R<br>(mm) | Max inflow<br>rectangular<br>3 pumps<br>(l/s) | Max inflow<br>circular<br>2 pumps<br>(l/s) | Disc. conn.<br>outlet<br>(mm) | Install<br>type | Flygt<br>product | Press.<br>type | B<br>(mm) |
|-----------|-----------|-----------|-----------|-----------|---|--|-------------------------------|-----------------|------------------|----------------|-----------|
| 2000      | 350       | 700       | 240       | 480       | 201   | 157  | 100                           | CP              | 3152             | SH             | 670       |
|           |           |           |           |           | 204   | 157  | 100, 150                      | CP              | 3152             | HT             | 680       |
|           |           |           |           |           | 192   | 157  | 80, 100                       | DP              | 3152             | HT             | 640       |
|           |           |           |           |           | 192   | 157  | 100                           | FP              | 3152             | HT             | 640       |
|           |           |           |           |           | 204   | 157  | 150                           | CP              | 3152             | MT             | 680       |
|           |           |           |           |           | 192   | 157  | 100                           | DP              | 3152             | MT             | 640       |
|           |           |           |           |           | 198   | 157  | 150                           | FP              | 3152             | LT             | 660       |
|           |           |           |           |           | 183   | 157  | 80, 100                       | NP              | 3153             | SH             | 610       |
|           |           |           |           |           | 183   | 157  | 100                           | NP              | 3153             | HT             | 610       |
|           |           |           |           |           | 201   | 157  | 150                           | NP              | 3153             | MT             | 670       |
|           |           |           |           |           | 201   | 157  | 100                           | NP              | 3171             | SH             | 670       |
| 201       | 157       | 100       | NP        | 3171      | HT  | 670  |                               |                 |                  |                |           |
| 2500      | 440       | 880       | 300       | 600       | 255   | 245  | 200                           | CP              | 3152             | MT             | 680       |
|           |           |           |           |           | 281   | 245  | 200                           | NP              | 3153             | LT             | 750       |
|           |           |           |           |           | 278   | 245  | 100, 150                      | CP              | 3170             | HT             | 740       |
|           |           |           |           |           | 278   | 245  | 150, 200                      | CP              | 3170             | MT             | 740       |
|           |           |           |           |           | 274   | 245  | 150                           | NP              | 3171             | MT             | 730       |
|           |           |           |           |           | 270   | 245  | 100                           | CP              | 3201             | SH             | 720       |
|           |           |           |           |           | 281   | 245  | 150, 200                      | CP              | 3201             | HT             | 750       |
|           |           |           |           |           | 289   | 245  | 150                           | NP              | 3202             | HT             | 770       |
|           |           |           |           |           | 330   | 245  | 150                           | RP              | 3231             |                | 880       |
|           |           |           |           |           | 319   | 245  | 200                           | CP              | 3300             | HT             | 850       |
| 311       | 245       | 150       | NP        | 3301      | HT  | 830  |                               |                 |                  |                |           |
| 3000      | 520       | 1040      | 360       | 720       | 437   | 353  | 250, 300                      | CP              | 3152             | LT             | 970       |
|           |           |           |           |           | 410   | 353  | 250                           | NP              | 3153             | LT             | 910       |
|           |           |           |           |           | 500   | 353  | 250, 300                      | CP              | 3170             | LT             | 1110      |
|           |           |           |           |           | 477   | 353  | 250                           | NP              | 3171             | LT             | 1060      |
|           |           |           |           |           | 468   | 353  | 250                           | CP              | 3201             | MT             | 1040      |
|           |           |           |           |           | 392   | 353  | 200                           | NP              | 3202             | MT             | 870       |
|           |           |           |           |           | 455   | 353  | 200                           | CP              | 3231             | 6 pole         | 1010      |
|           |           |           |           |           | 518   | 353  | 200                           | CP              | 3231             | 4 pole         | 1150      |
|           |           |           |           |           | 531   | 353  | 300                           | CP              | 3300             | MT             | 1180      |
| 518       | 353       | 250       | NP        | 3301      | MT  | 1150                                       |                               |                 |                  |                |           |
| 3500      | 620       | 1230      | 420       | 840       | 646   | 481  | 300, 350                      | CP              | 3201             | LT             | 1230      |
|           |           |           |           |           | 688   | 481  | 300                           | NP              | 3202             | LT             | 1310      |
|           |           |           |           |           | 704   | 481  | 350                           | CP              | 3300             | LT             | 1340      |

Flygt pump 3201, see Design recommendations for large wastewater pumps.

## Circular

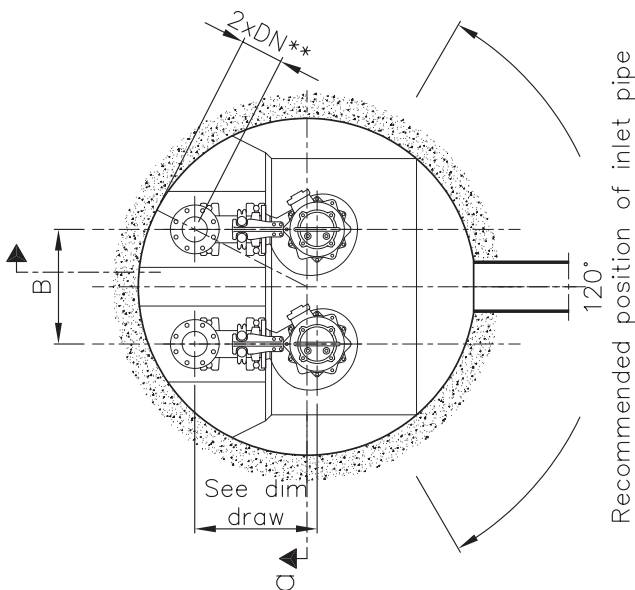
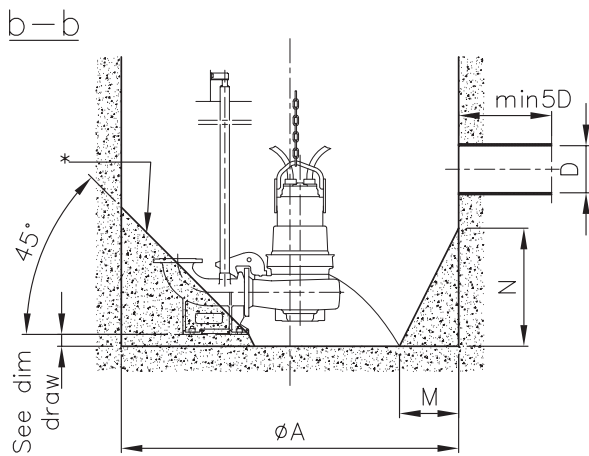
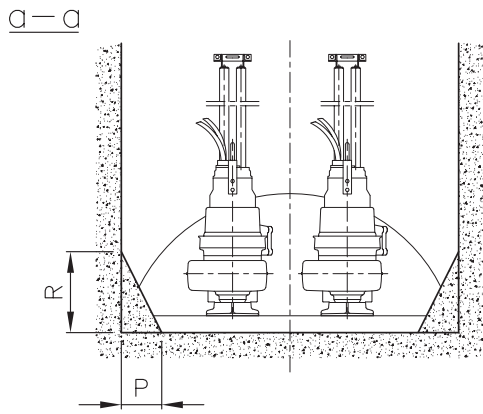

Recommended position of inlet pipe

DN = Outlet of discharge connection.

\* If any pumps in the sump is to be equipped with a flush valve, this benching may need to be modified. Please contact ITT Water & Wastewater for detailed advice.

\*\* Check that there is enough space for valves, bends etc. on the discharge pipe.

## Rectangular

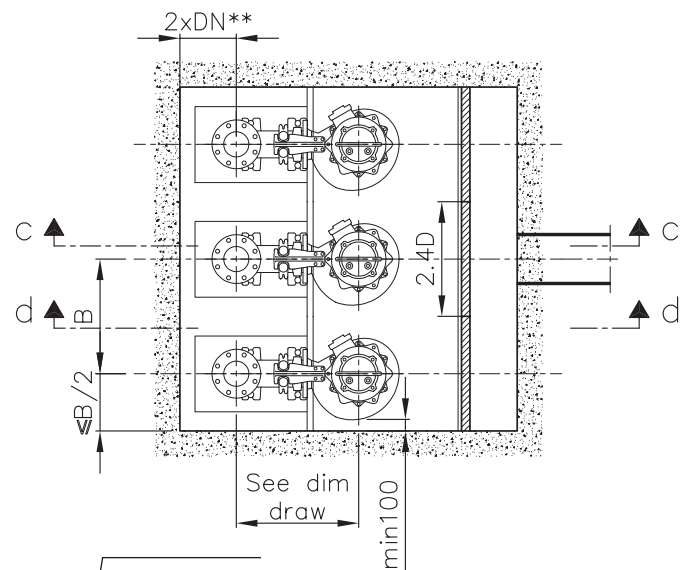
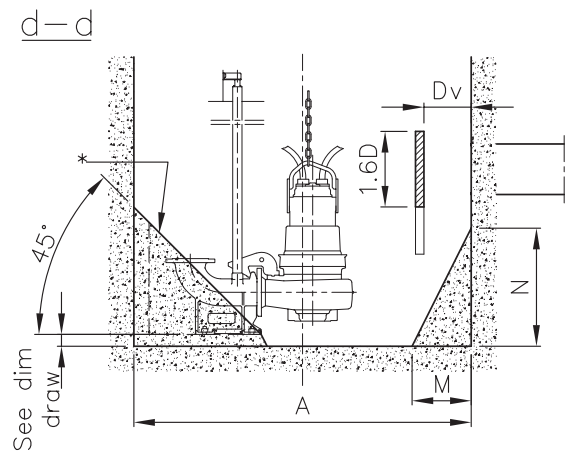
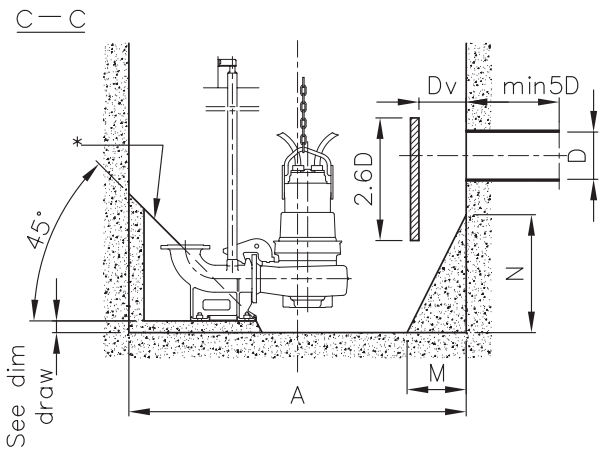

$$D_v = \sqrt{\frac{4 \cdot Q_{\text{tot}}}{1.8 \cdot p}} \quad \text{where } D_v \text{ in m, } Q_{\text{tot}} \text{ in m}^3/\text{s}$$

If the distance between the centerline of the pump station inlet and the sump bottom is  $> 2N$  the inner design of the sump may need to be modified. Please contact Flygt for detailed advice.

If three pumps are to be installed an inlet baffle should be used.

## Required volumes

The starting frequency of the pump depends on the inflow to the sump and the volume between start and stop levels - the "active" or "storage" volume. The real inflow to a sewage pumping station will never be constant. It will differ according to the time of the day, the weather, and the location of the station within the system.

If the maximum value of the inflow is used as a constant inflow value, the volume will be overestimated. This results in long periods of pump inactivity i.e. at night and in dry-weather. This can lead to problems as the sediment settles on the sump floor and floating materials accumulate on the surface. The settled sediment may cause clogging at start and noxious gases may build-up. Blockages of this sort are one of the most common causes of emergency call-outs for pump failure. One way of solving the problem is to reduce the sump volume, which consequently increases the starting frequency. For Flygt pumps, 15 starts/hour are possible without endangering the life of the pump.

## Calculating the active sump volume

The required active volume of the sump,  $V$  ( $m^3$ ), i.e. the volume between the start level and the stop level, depends upon such factors as the cycle time for the pump,  $T$  (seconds), the pump capacity,  $Q$  ( $m^3/sec$ ), and the rate of the inflow,  $q$  ( $m^3/sec$ ).

When one pump is operating with variable inflow rate, the shortest cycle time occurs if  $q = Q/2$  which gives the minimum required volume of the sump:

$$V_{min} = T_{min} \times Q / 4$$

The minimum cycle time, (is determined by the number of pump starts with regard to the mechanical stress from the temperature rise in the motor. Assuming 15 starts per hour implies a critical cycle time  $T$  of 240 seconds, the above equation becomes:

$$V_{min} = 240 \times Q_{pump} / 4$$

where

$Q_{pump}$ : individual pump capacity in  $l/s$  or  $m^3/s$  (in  $l$  or  $m^3$  respectively).

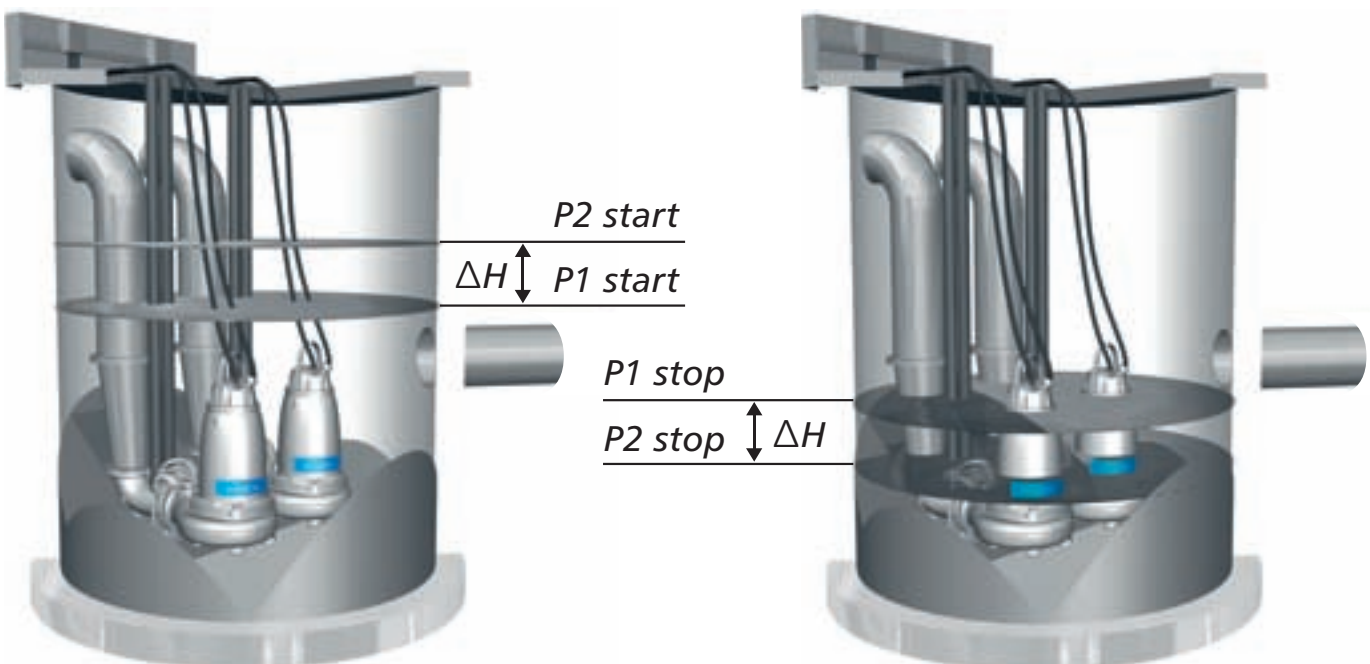

Start and stop levels in a pump sump

For pump stations with several identical pumps, the required volume of the sump can be minimized if the pumps start in sequence as the water level rises due to increasing inflow and stop in the reverse order as the water level drops due to decreasing inflow. The start and stop levels of all pumps differ by a constant value  $\Delta H$  (see illustration on this page) that is determined by the characteristics of the control system.  $\Delta H$  should be large enough to eliminate accidental pump starts that could be caused by surface waves or imprecise level sensors. In general, the total volume required for a sump with  $n$  pumps and a constant value  $H$  is

$$V_{tot,n} = V_{min} + (n-1) \times \Delta H \times S$$

in which  $S$  is the plan area of the sump and  $V_{min}$  is the volume required for a single pump. A signifi-

cant reduction of the required sump can be achieved if cyclic alternation of the pump is used. In this case, the required volume for one pump equals the volume that is required without alternating, divided by the total number of pumps in the alternative cycle,  $n$ .

$$V_{tot,n} = 240 \times Q_{pump} / (4 \times n) + (n-1) \times \Delta H \times S$$

If a pump station consists of several pumps of different capacities, the required volume for each pump, or group of identical pumps, must be determined separately.

The combined required sump volume will depend on operating requirements for the pump station and must be analysed in each case.

## Systems Engineering

ITT Water & Wastewater offers in-depth expertise in the design and execution of comprehensive solutions for water and wastewater transport and treatment.

Our know-how and experience are combined with a broad range of suitable products for delivering customized solutions that ensure trouble-free operations for customers. To do this our engineers utilize our own specially developed computer programs, as well as commercial, for design and development projects.

Scope of assistance includes a thoroughgoing analysis of the situation and proposed solutions – together with selection of products and accessories.

We also provide hydraulic guidance and assistance for flow-related or rheological issues. Customers turn to us, as well, for analysis of complex systems for network pumping, including calculations for hydraulic transients, pump starts and flow variations.

### Additional services:

- Optimization of pump sump design for our products and specific sites

- Assistance with mixing and aeration specifications and design of appropriate systems
- System simulation utilizing computational fluid dynamics (CFD)
- Guidance for model testing – and organizing it
- Guidance for achieving the lowest costs in operations, service and installation
- Specially developed engineering software to facilitate designing

The range of services is comprehensive, but our philosophy is very simple: There is no substitute for excellence.





### What can ITT Water & Wastewater do for you?

Integrated solutions for fluid handling are offered by ITT Water & Wastewater as a world leader in transport and treatment of wastewater. We provide a complete range of water, wastewater and drainage pumps, equipment for monitoring and control, units for primary and secondary biological treatment, products for filtration and disinfection, and related services. ITT Water & Wastewater, headquartered in Sweden, operates in some 140 countries across the world, with own plants in Europe, China and North and South America. The company is wholly owned by the ITT Corporation of White Plains, New York, supplier of advanced technology products and services.

[www.ittwww.com](http://www.ittwww.com)



WEDECO

